



栅极驱动光耦  
Gate Drive Optocoupler

**AT350**

台湾奥特半导体科技有限公司  
TAIWAN AOTE SEMICONDUCTOR TECHNOLOGY CO.,LTD  
台湾台中市丰原中阳里圆环东路569号  
569 Yuanhuan East Road, Zhongyangli, Fengyuan, Taichung, Taiwan

### 概述 Description

AT350 是一种输出电流为 2.5A 的栅极驱动光电耦合器，具有一个砷化铝镓 (AlGaAs) 发光二极管，通过红外光耦合到光敏集成电路。这种光电耦合器可驱动大多数的小功率 IGBTs 和 MOSFETs。在电机控制逆变器以及高性能电力系统应用中，其非常适用于快速切换驱动功率 IGBTs 和 MOSFETs

The AT350 is a gate driven optocoupler with an output current of 2.5 A, with an GaAsP LED, which is coupled to a photosensitive integrated circuit through infrared light. This optocoupler can drive most low-power IGBTs and MOSFETs. In the motor control inverter and high-performance power system applications, it is very suitable for fast switching drive power IGBTs and MOSFETs.

### 特性 Features

- 2.5A 最小峰值输出电流  
2.5A Minimum peak output current
- 25kV/us 最小共模抑制( $V_{CM}=1500V$ )  
25kV/us minimum Common Mode Rejection ( $V_{CM}=1500V$ )
- 带滞后欠压锁定(UVLO)  
Locking with hysteresis (UVLO)
- 宽工作电压范围：15V 到 32V  
Wide operating  $V_{CC}$  Range: 15V ~ 32V
- 工作温度范围：-40°C to +110°C  
Operating temperature range: -40°C ~ +110°C
- 0.5V 最大低电平输出电压( $V_{OL}$ )  
0.5V Maximum Low Level Output Voltage ( $V_{OL}$ )
- 符合加强绝缘标准  
Meet reinforced insulation standards

### 应用 Applications

- 隔离 IGBT/MOSFET 门驱动  
Isolation of the IGBT / MOSFET gate drive
- 交流和无刷直流电机驱动  
AC and brushless DC motor drive
- 感应炉顶  
Induction furnace top
- 工业逆变器  
Industrial inverter
- 开关电源(SMPS)  
Switch power supply (SMPS)
- 不间断电源(UPS)  
Uninterruptible power supply (UPS)

### 真值表 Truth table

LED	$V_{CC}-V_{EE}$ " POSITIVE GOING" (TURN-ON)	$V_{CC}-V_{EE}$ "NEGATIVE GOING" (TURN-OFF)	VO
OFF	0 ~ 30V	0 ~ 32V	LOW
ON	0 ~ 11V	0 ~ 9.5V	LOW
ON	11 ~ 13.5V	9.5 ~ 12V	TRANSITION
ON	13.5 ~ 32V	12 ~ 32V	HIGH

### 封装和原理图 Package and Schematic Diagram

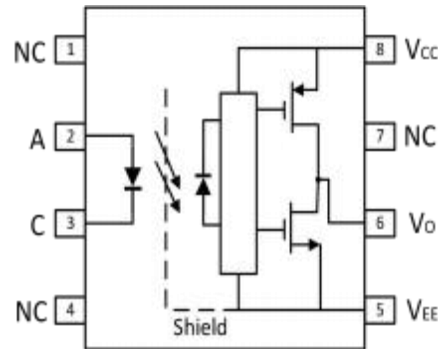
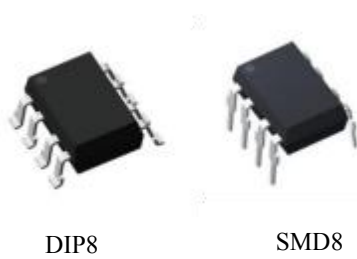

#### Pin Configuration

- 1, 4 NC
- 2 Anode
- 3 Cathode
- 5 VEE
- 6 VO
- 7 NC
- 8 VDD

注：在引脚 5 和 8 之间必须连接一个 0.1uF 的旁路电容器。

Note: A 0.1uF bypass capacitor must be connected between pins 5 and 8.



### 产品型号命名规则 Order Code

## AT 350 - UN Y - W (V) (ZZ)

①                      ②                      ③                      ④                      ⑤                      ⑥                      ⑦

- ① 公司代码 Company Code (AT: 奥特 Aote)
- ② 产品系列 Product Series (350)
- ③ 框架类型 Lead Frame (Cu: 铜框架 Copper)
- ④ 树脂类型 Epoxy (H: 无卤 Halogen-free, L: 有卤/无铅 Halogen/Lead-free)
- ⑤ 封装形式 Package (S: SMD)
- ⑥ 器件工作温度范围 Device Operating Temperature Range (特殊范围需填或者空白 Special Range need to be filled in or left blank)
- ⑦ 内部补充代码 Internal Supplementary Code (数字或者空白 Number or None)

### 印字信息 Marking Information

- 印字中 “” 为奥特品牌 LOGO  
“” denotes LOGO
- 印字中 “Y” 代表年份：A(2018), B(2019), C(2020) ... ...  
“Y” denotes YEAR：A(2018), B(2019), C(2020) ... ...
- 印字中 “WW” 代表周号  
“WW” denotes Week’s number
- 印字中 “N” 代表星期几  
“N” denotes the day of the week
- 印字中的 “H” 代表无卤，而当产品有卤/无铅时，此处空白  
“H” denotes Halogen-free, when the product has halogen/lead-free, leave this blank.

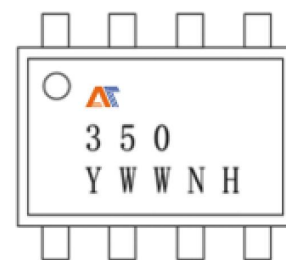

### 绝缘和安规信息 Insulation and Safety related specifications

项目 Item	符号 Symbol	数值 Value	单位 Unit	备注 Note
爬电距离 Creepage Distance	L	≥7	mm	从输入端到输出端，沿本体最短距离路径 Measured from input terminals to output terminals, shortest distance path along body.
电气间隙 Clearance Distance	L	≥7	mm	从输入端到输出端，通过空气的最短距离 Measured from input terminals to output terminals, shortest distance through air.
绝缘距离 Insulation Thickness	DTI	≥0.4	mm	发射器和探测器之间的绝缘厚度 Insulation thickness between emitter and detector.
峰值隔离电压 Peak Isolation Voltage	V <sub>IORM</sub>	1500	V <sub>peak</sub>	DIN/EN/IEC EN60747-5-5.
瞬态隔离电压 Transient Isolation Voltage	V <sub>IOTM</sub>	7000	V <sub>peak</sub>	DIN/EN/IEC EN60747-5-5.
隔离电压 Isolation Voltage	V <sub>ISO</sub>	5000	V <sub>rms</sub>	For 1 min

### 极限参数 Absolute Maximum Ratings (T<sub>A</sub> = 25°C)

参数 Parameter		符号 Symbol	最小值 Min.	最大值 Max.	单位 Unit
输入 Input	正向输入电流 Forward Input Current	I <sub>F</sub>	-	25	mA
	峰值瞬态输入电流 (<1 μs 脉冲宽度, 300 pps) Peak Transient Input Current (<1 μs Pulse Width, 300 pps)	I <sub>F(TRAN)</sub>	-	1	A
	反向电压 Reverse Voltage	V <sub>R</sub>	-	5	V
	输入功率 Power Dissipation	P <sub>I</sub>	-	45	mW
输出 Output	高峰值输出电流 High Peak Output Current	I <sub>OH(PEAK)</sub>	-	2.5	A
	低峰值输出电流 Low Peak Output Current	I <sub>OL(PEAK)</sub>	-	2.5	A
	电源电压 Supply Voltage	V <sub>CC-V<sub>EE</sub></sub>	0	35	V
	输出电压 Output Voltage	V <sub>O(PEAK)</sub>	0	V <sub>CC</sub>	V
	输出功率 Power Dissipation	P <sub>O</sub>	-	250	mW
总功率耗散 Total Power Dissipation		P <sub>tot</sub>	-	295	mW
存储温度 Storage Temperature		T <sub>S</sub>	-55	+125	°C
工作温度 Operating Temperature		T <sub>A</sub>	-40	+110	°C
焊接温度 Soldering Temperature		T <sub>Sol</sub>	-	260	°C

### 推荐操作条件 Recommended Operating Conditions

参数 Parameter	符号 Symbol	最小值 Min	最大值 Max	单位 Unit
电源电压 Power Supply Voltage	$V_{CC}-V_{EE}$	15	32	V
开启电流 Input Current (ON)	$I_{F(ON)}$	7	16	mA
关断电压 Input Voltage (OFF)	$V_{F(OFF)}$	-3	0.8	V
工作温度 Operating Temperature	$T_A$	-40	+110	°C

### 产品特性参数 Electro-optical Characteristics ( $T_A = 25^\circ\text{C}$ )

在推荐的工作条件下测试最小值和最大值，除非另有规定，所有典型值在  $T_A = 25^\circ\text{C}$ ， $V_{CC}-V_{EE}=30\text{V}$  时测得。

All minimum and maximum specifications are at recommended operating conditions, unless otherwise noted.

All typical values are at  $T_A = 25^\circ\text{C}$ ,  $V_{CC}-V_{EE}=30\text{V}$ .

参数 Parameter	符号 Symbol	条件 Condition	最小 Min.	典型 Typ.	最大 Max.	单位 Unit
高电平输出电流 High Level Peak Output Current	$I_{OH}$	$V_O = V_{CC}-4\text{V}$	0.5	-	-	A
		$V_O = V_{CC}-15\text{V}$	2.5	-	-	
低电平输出电流 Low Level Peak Output Current	$I_{OL}$	$V_O = V_{EE}+2.5\text{V}$	0.5	-	-	A
		$V_O = V_{EE}+15\text{V}$	2.5	-	-	
高电平输出电压 High Level Output Voltage	$V_{OH}$	$I_O = -100\text{mA}$	$V_{CC}-0.3$	$V_{CC}-0.1$	-	V
低电平输出电压 Low Level Output Voltage	$V_{OL}$	$I_O = 100\text{mA}$	-	0.08	0.5	V
高电平电源电流 High Level Supply Current	$I_{CCH}$	输出开路, $I_F = 7\text{mA}$ to $16\text{mA}$	-	-	2.5	mA
低电平电源电流 Low Level Supply Current	$I_{CCL}$	输出开路, $V_F = -3\text{V}$ to $+0.8\text{V}$	-	-	2.5	mA
低到高输入阈值电流 Threshold Input Current Low to High	$I_{FLH}$	$I_O = 0\text{mA}$ , $V_O > 5\text{V}$	-	-	5	mA
高到低输入阈值电压 Threshold Input Voltage High to Low	$V_{FHL}$	$I_O = 0\text{mA}$ , $V_O < 5\text{V}$	0.8	-	-	V
输入正向电压 Input Forward Voltage	$V_F$	$I_F = 10\text{mA}$	1	-	1.6	V
输入正向电压的温度系数 Temperature Coefficient of Input Forward Voltage	$\Delta V_F / \Delta T_A$	$I_F = 10\text{mA}$	-	-1.4	-	mV/°C
输入反向电压 Input Reverse Voltage	$B_{VR}$	$I_R = 10\mu\text{A}$	5	-	-	V
输入电容 Input Capacitance	$C_{IN}$	$f = 1\text{MHz}$ , $V_F = 0\text{V}$	-	43	-	pF

参数 Parameter	符号 Symbol	条件 Condition	最小 Min.	典型 Typ.	最大 Max.	单位 Unit
欠压锁定阈值 UVLO Threshold	$V_{UVLO+}$	$V_O > 5V, I_F = 10mA$	11	-	13.5	V
	$V_{UVLO-}$	$V_O < 5V, I_F = 10mA$	9.5	-	12	
低电压锁定阈值迟滞 UVLO Hysteresis	$UVLO_{HYS}$	-	-	1.5	-	V
逻辑低电平传输延迟 Propagation Delay Time to Low Output Level	$t_{PHL}$	$R_g = 10\Omega, C_g = 10nF,$ $f = 10kHz, \text{占空比} = 50\%$	0.1	-	0.4	us
逻辑高电平传输延迟 Propagation Delay Time to High Output Level	$t_{PLH}$		0.1	-	0.4	
脉宽失真 Pulse Width Distortion	PWD		-	-	0.2	
输出上升时间 Output Rise Time	$t_R$		-	0.017	-	
输出下降时间 Output Fall Time	$t_F$		-	0.012	-	
UVLO 导通延迟 UVLO Turn on delay	$t_{UVLO ON}$	$V_O > 5V, I_F = 10mA$	-	0.8	-	us
UVLO 关断延迟 UVLO Turn off delay	$t_{UVLO OFF}$	$V_O < 5V, I_F = 10mA$	-	0.6	-	us
输出高电平共模瞬态抑制 Output High Level Common Mode Transient Immunity	$ CM_H $	$T_A = 25^\circ C,$ $I_F = 10 \sim 16mA,$ $V_{CM} = 1500V, V_{CC} = 30V$	25	35	-	kV/us
输出低电平共模瞬态抑制 Output Low Level Common Mode Transient Immunity	$ CM_L $	$T_A = 25^\circ C, V_F = 0V,$ $V_{CM} = 1500V, V_{CC} = 30V$	25	35	-	kV/us

### 典型光电特性曲线 Typical Electro-Optical Characteristics Curves

Fig.1 High Output Voltage Drop vs Ambient Temperature

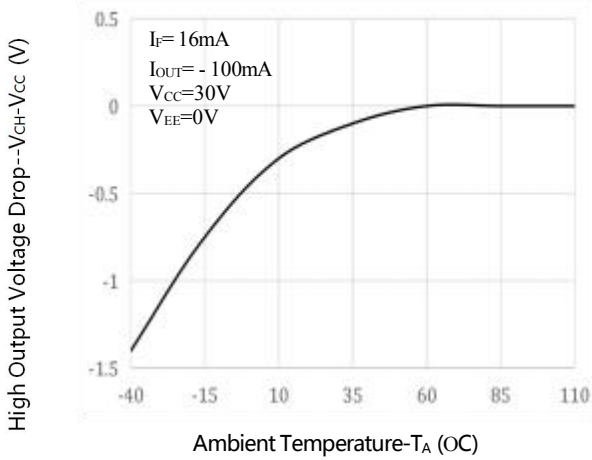

Fig.2 High Level Output Voltage vs Ambient Temperature

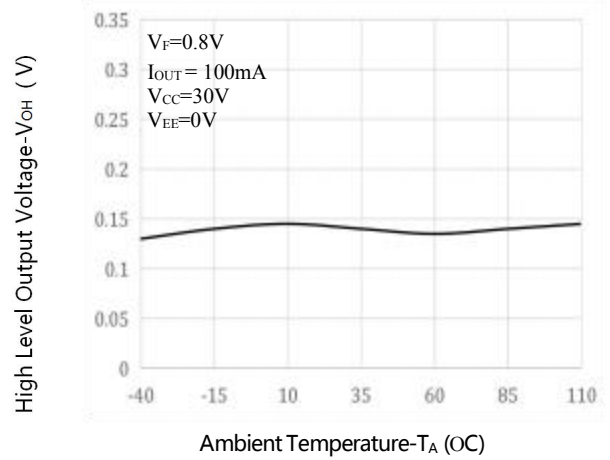

Fig.5 Low Level Output Voltage vs Low Level Output Current

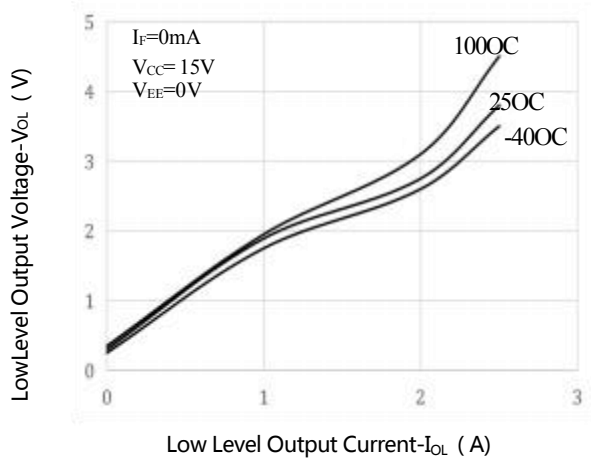

Fig.6 Supply Current vs Supply Voltage

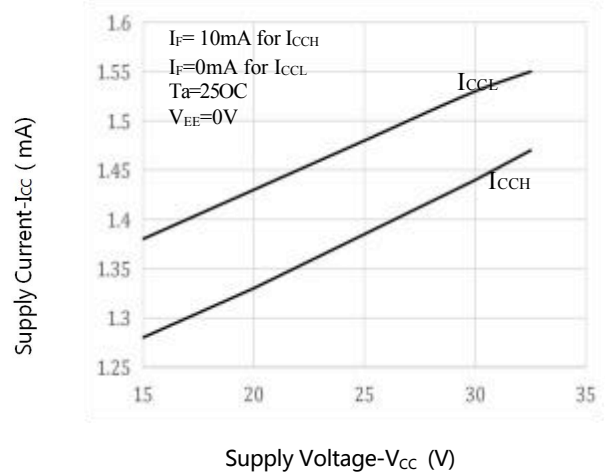

Fig.7 High Output Voltage Drop vs High Level Output Current

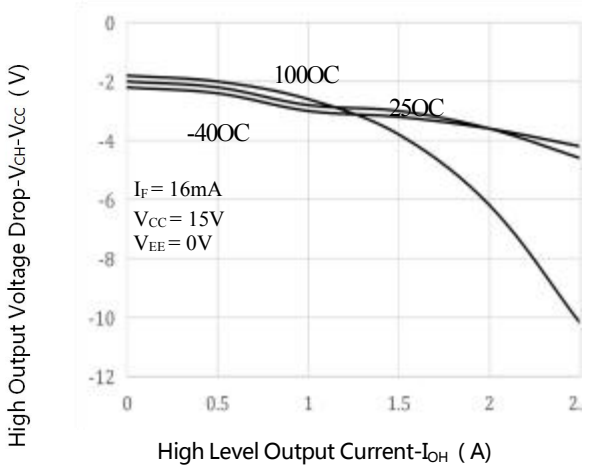

Fig.8 Threshold Input Current Low to High vs Ambient Temperature

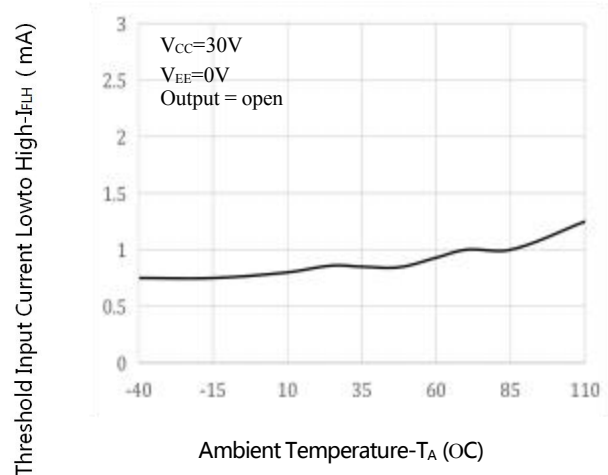

Fig.9 Supply Current vs Ambient Temperature

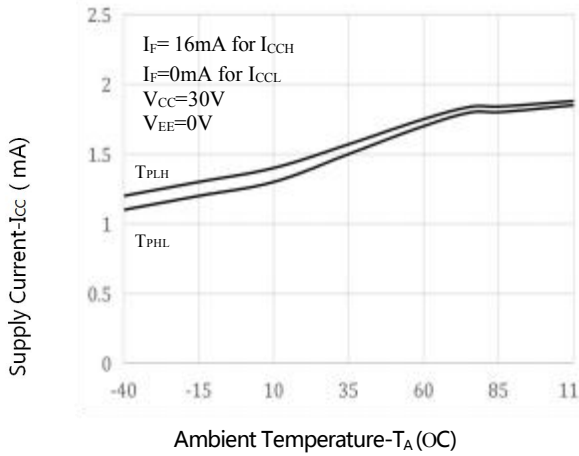

Fig.10 Transmission Characteristics

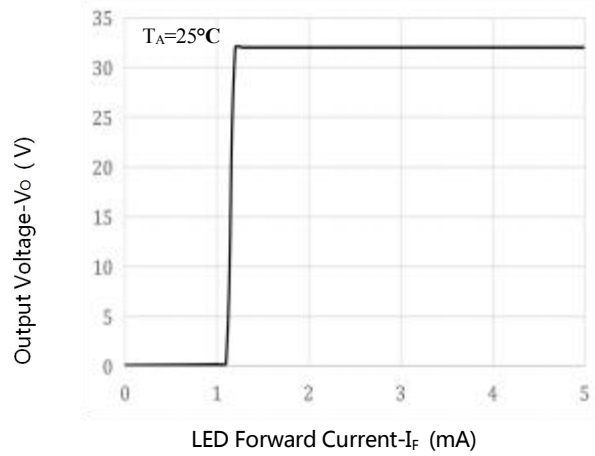

Fig.11 Propagation Delay vs Supply Current

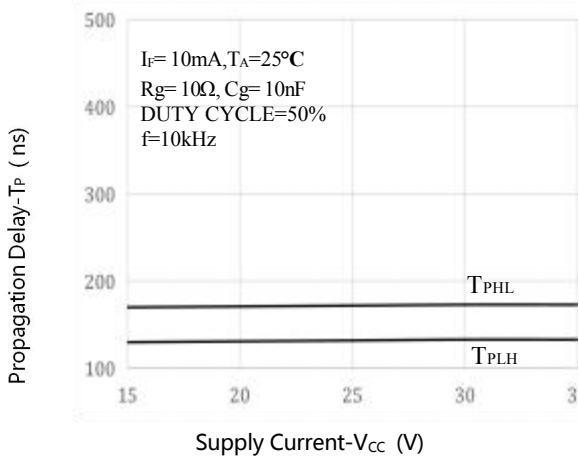

Fig.12 Propagation Delay vs Load Resistance

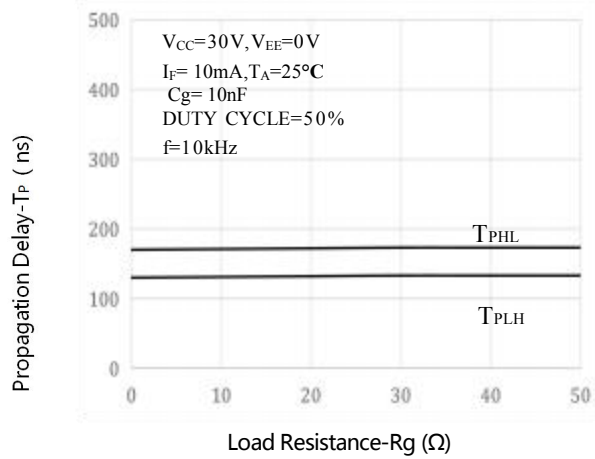

Fig.13 Propagation Delay vs Ambient Temperature

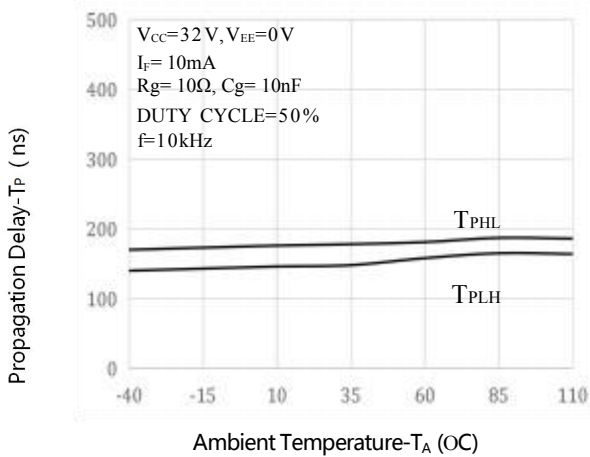

Fig.14 Propagation Delay vs Load Capacitor

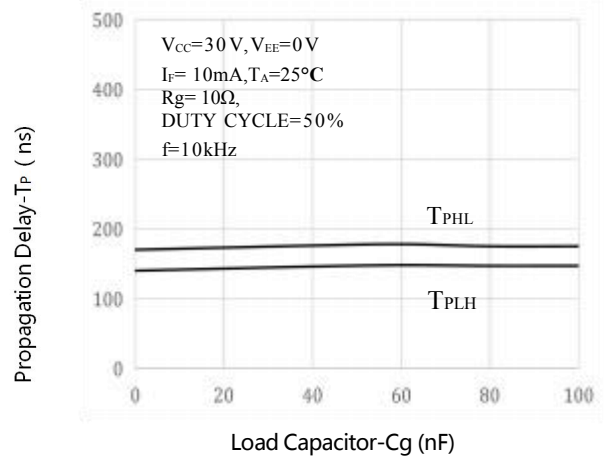
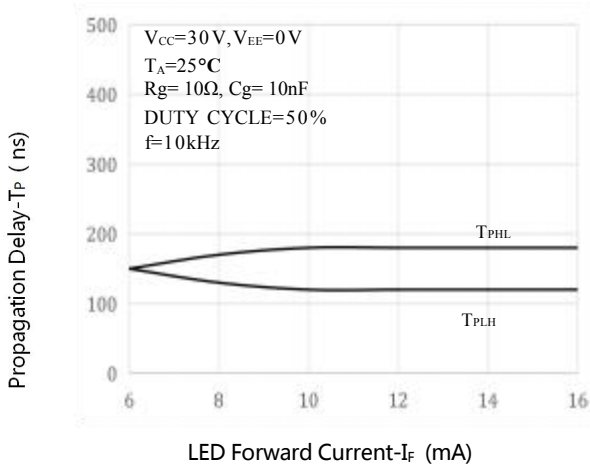



Fig.15 Propagation Delay vs LED Forward Current



### 测试电路 Test Circuit

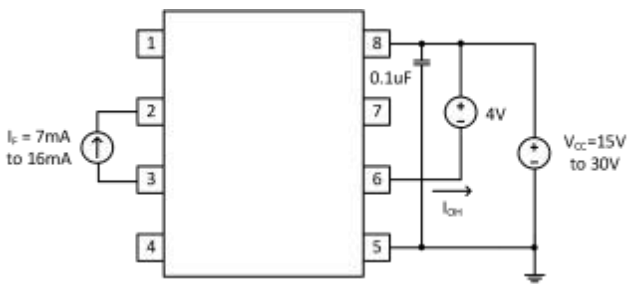

Fig.16  $I_{OH}$  Pulsed Test Circuit

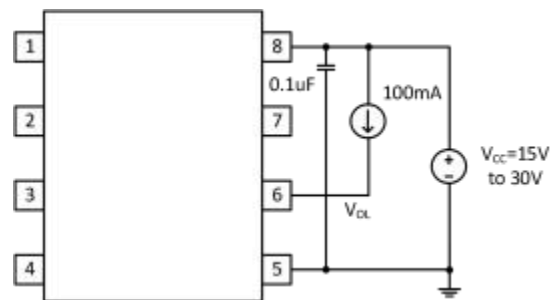

Fig.17  $V_{OL}$  Pulsed Test Circuit

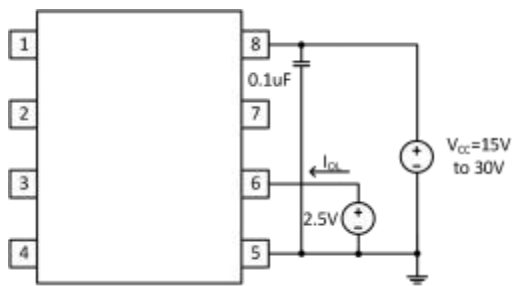

Fig.18  $I_{OL}$  Pulsed Test Circuit

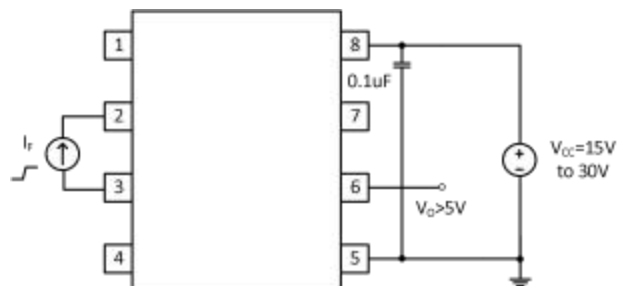

Fig.19  $I_{FLH}$  Test Circuit

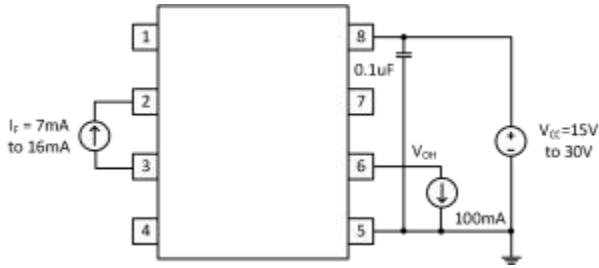

Fig.20  $V_{OH}$  Pulsed Test Circuit

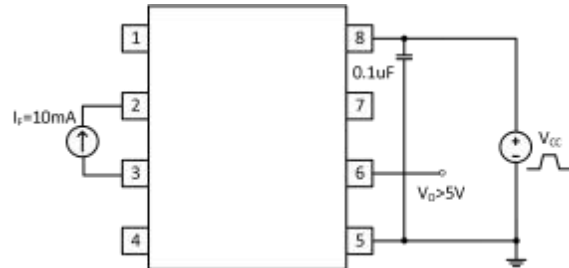

Fig.21 UVLO Test Circuit

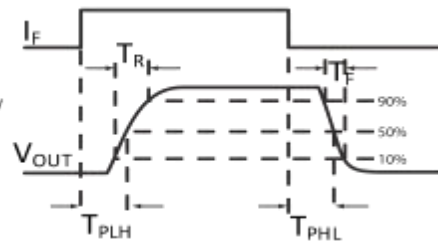
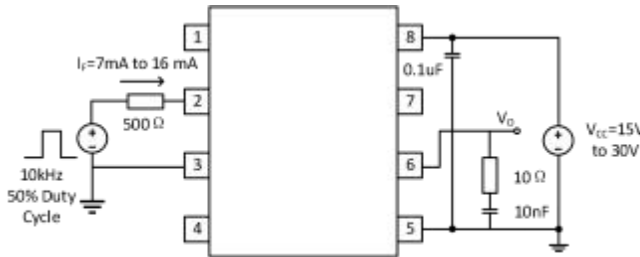

Fig.22  $T_{PHL}$ 、 $T_{PLH}$ 、 $T_R$ 、 $T_F$  Test Circuit

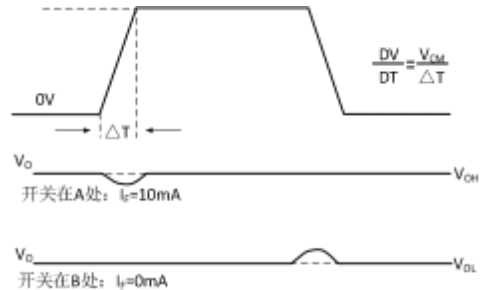
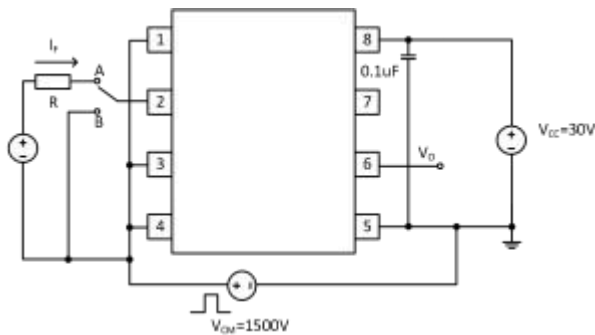
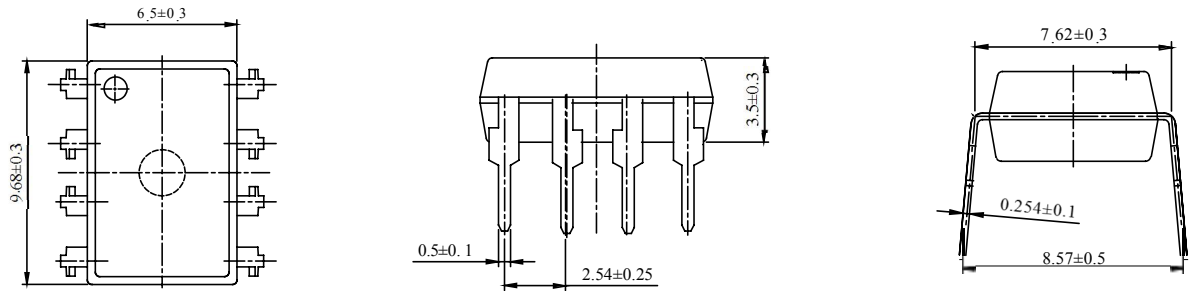

Figure.23 CMR Test Circuit

### 外形尺寸 Outline Dimensions

#### DIP8



#### SMD8

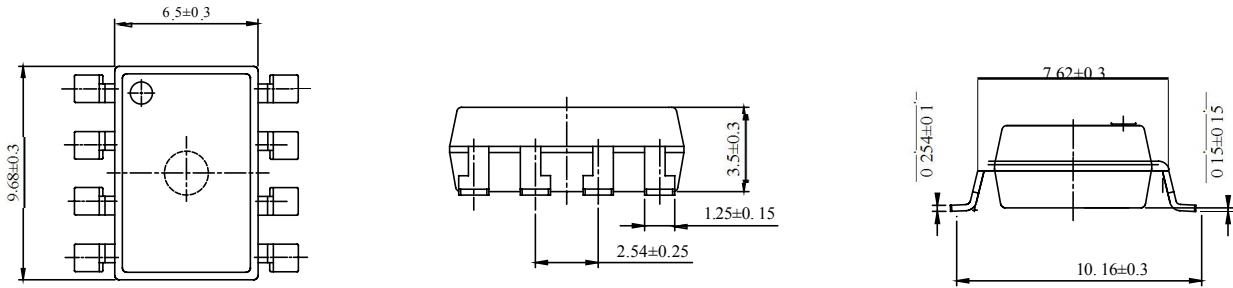

单位 Unit: mm

### 建议焊盘布局 Recommended Pad Layout

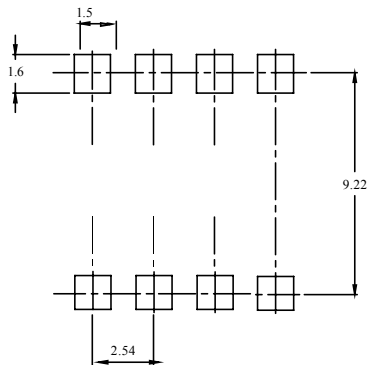

单位 Unit: mm

注：上图为产品正视图。

Note: The picture above is the front view of the product.

### 回流焊温度曲线图 Solder Reflow Profile

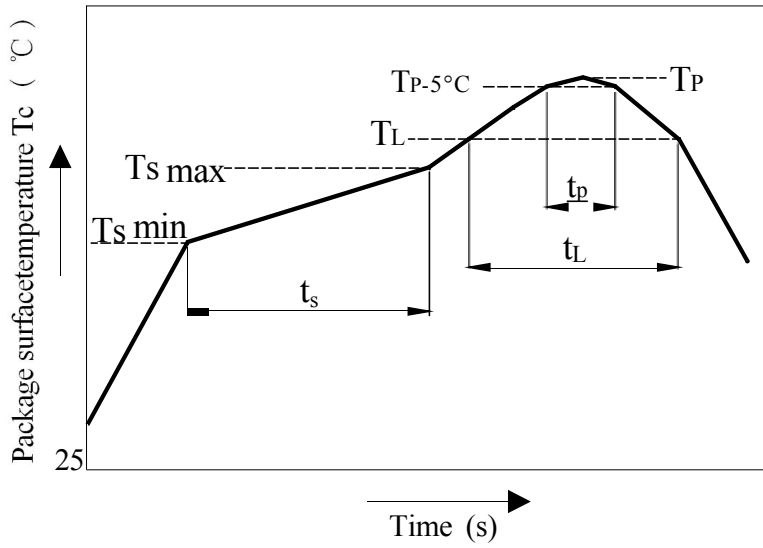

项目 Item	符号 Symbol	最小值 Min.	最大值 Max.	单位 Unit
预热温度 Preheat Temperature	$T_s$	150	200	$^\circ\text{C}$
预热时间 Preheat Time	$t_s$	60	120	s
升温速率 Ramp-Up Rate ( $T_L$ to $T_P$ )	-	-	3	$^\circ\text{C}/\text{s}$
液相线温度 Liquidus Temperature	$T_L$	217		$^\circ\text{C}$
时间高于 $T_L$ Time Above $T_L$	$t_L$	60	150	s
峰值温度 Peak Temperature	$T_P$	-	260	$^\circ\text{C}$
$T_c$ 在 ( $T_P - 5$ ) 和 $T_P$ 之间的时间 Time During Which $T_c$ Is Between ( $T_P - 5$ ) and $T_P$	$t_p$	-	30	s
降温速率 Ramp-down Rate ( $T_P$ to $T_L$ )	-	-	6	$^\circ\text{C}/\text{s}$

注：建议在所示的温度和时间条件下进行回流焊，最多不能超过三次。

Note: Reflow soldering is recommended at the temperatures and times shown, no more than three times.

### 波峰焊温度曲线图 Wave Soldering Profile

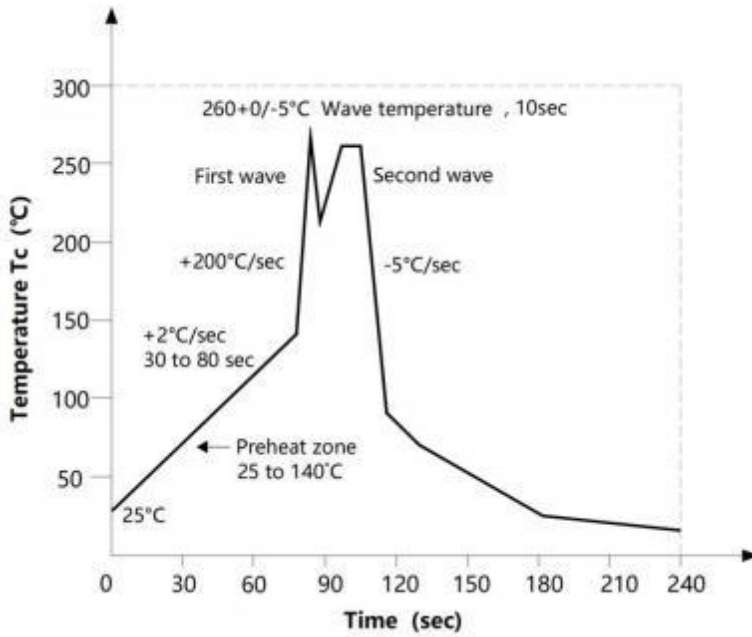

### 手工烙铁焊接 Soldering with hand soldering iron

- A. 手工烙铁焊仅用于产品返修或样品测试；  
Hand soldering iron is only used for product rework or sample testing;
- B. 手工烙铁焊要求：温度  $360^{\circ}\text{C} \pm 5^{\circ}\text{C}$ ，时间  $\leq 3\text{s}$ 。  
Manual soldering method Temperature:  $360^{\circ}\text{C} \pm 5^{\circ}\text{C}$ , within 3s.

### 包装 Packing

#### ■ 汇总表 Summary table

封装形式	包装方式	盘数量	盒数量	箱数量	静电袋规格	盒规格	箱(双瓦楞)规格	备注
SMD8	卷盘 ( $\phi$ 330mm 蓝盘)	1k/盘	2 盘/盒	10 盒/箱	450*390*0.1mm	340*60*340mm	380*360*365mm	首端空 50 个空格, 末端空 100
DIP8	管装 (500*12*11mm)	45/管	50 管/盒	10 盒/箱	不适用	525*128*56mm	535*275*300mm	每管使用蓝白胶塞, 方向须一致
Package Type	Packing Form	Quantity per Reel	Quantity per Box	Quantity per Carton	Antistatic Bag Specification	Box Specification	Carton Specification	Note
SMD8	Tube ( $\phi$ 330mm Blue)	1k pcs/reel	2 reels /box	10 boxes /ctn	450*390*0.1mm	340*60*340mm	380*360*365mm	Leave 50 Spaces at the beginning and 100 Spaces at the end
DIP8	Reel (500*12*11mm)	45 pcs/Tube	50 Tubes/box	10 boxes/ctn	Not applicable	525*128*56mm	535*275*300mm	Use blue and white rubber stoppers for each tube, with the same direction

#### ■ 管条包装 Tape & Tube

- 1) 每管数量：45 只。  
Qty/Tube：45 pcs.
- 2) 每箱数量：22500 只。  
Qty/ctn：22500 pcs.
- 3) 内包装：每盒 50 管。  
Inner packing：50 Tubes/box.
- 4) 示意图 Schematic：

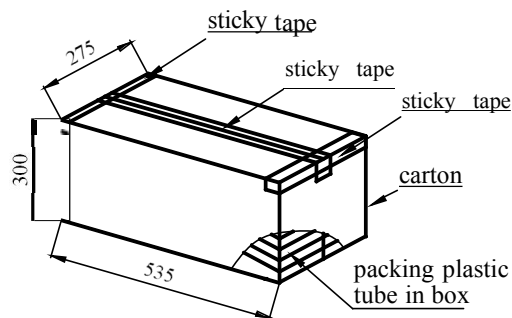
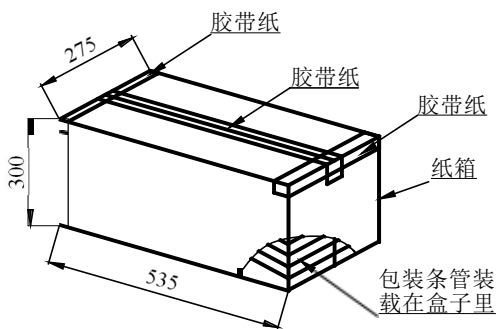

### ■ 编带包装 Tape & Reel

- 1) 每卷数量：1000 只。  
Qty/reel：1000 pcs.
- 2) 每箱数量：20000 只。  
Qty/ctn：20000 pcs.
- 3) 内包装：每盒 2 盘。  
Inner packing：2 reels/box.
- 4) 示意图 Schematic：

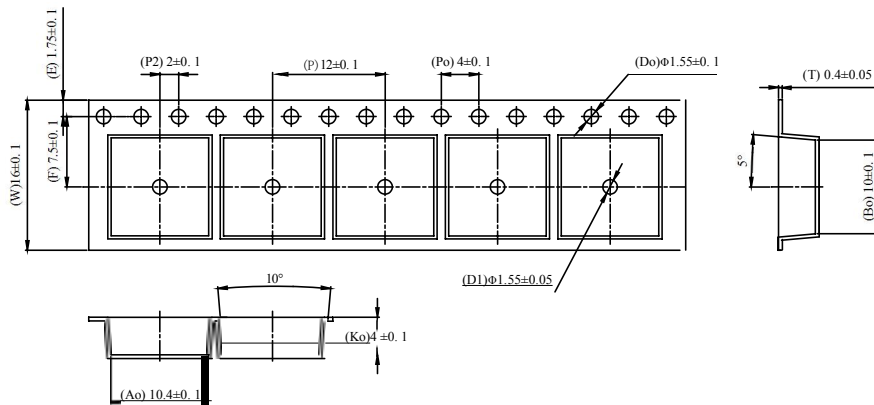

单位 Unit：mm

### 注意 Attention

- 奥特持续不断改进质量、可靠性、功能或设计，保留此文件更改的权利恕不另行通知。  
AOTE continuously improve quality, reliability, function or design. We reserve the right to change this document without notice.
- 请遵守产品规格书使用，奥特不对使用时不符合产品规格书条件而导致的质量问题负责。  
Please use in accordance with the product specification. AOTE is not responsible for the quality problems caused by non-compliance with the product specifications.
- 对于需要高可靠性或安全性的设备/装置需求，请联系我们的销售人员。  
For equipment/devices where high reliability or safety is required, please contact our sales representatives.
- 当需要用于任何“特定”应用时，请咨询我们的销售人员。  
When requiring a device for any “specific” application, please contact our sales in advice.
- 如对文件中表述的内容有疑问，欢迎联系我们。  
If you have any questions about the contents of the document, please contact us.